

PRODUCT  
**SERVO 300**

DESCRIPTION  
**POWER AMPLIFIER**

SERIES  
**SERVO**

CATEGORY  
**AMPLIFIERS**



**GENERAL DESCRIPTION**

The Samson Servo 300 stereo power amplifier has been designed to provide robust, clean output with low distortion and wide dynamic range, along with the dependability demanded by the most professional audio engineers and installers.

Their convenient 2 rack-space design is compact, and yet there's plenty of power available, with 2 x 100 Watts at 8Ω, 2 x 150 Watts at 4Ω over the full frequency spectrum, from 10 Hz to 55 kHz.

For mono applications, a Bridge mode links both channels of the amplifiers, thus providing even more single channel power, with a power ratings of 300 watts into an 8 Ohm load.

Input connections are available for both unbalanced RCA connections and balanced 1/4-inch TRS connections. For the outputs, the Servo 300 amplifier provides standard 5-way binding posts and 1/4" phone jacks. Front-panel controls and displays include a power switch with LED indicator, as well as independent left and right channel input level controls. To help you set the correct operating levels, the Servo 300 amplifier includes front panel Signal, Peak and Protection LED indicators. There's also a ten-segment VU meter to help you set a good operating level.

Like all serious power amplifiers, the Servo 300's internal electronics are based around a serious power-core, with a over-sized toroidal transformer and large extruded heat sinks. To keep the Servo 300 amplifier

running cool, the design employs twin internal wind tunnels with forced-air cooling via two temperature-sensitive, variable speed fans, which greatly reduce the chance of thermal and overheating problems. Multi-stage protection for power-up, over-heating, over-current, short circuit, low output impedance and DC voltage, assures high reliability under the most demanding situations.

The Servo 300 amp is road tough with its all steel chassis and 19-inch rack mount design. The Servo 300 amplifier is ready for a life on the road, or to make its home in a fixed installation.

Optimized for live sound venues, houses of worship, commercial installations, and for driving small and medium-sized live PA systems, the Servo Series amplifiers will deliver reliable power from gig-to-gig, venue-to-venue and day-to-night.

**FEATURES**

- > Power to spare - 2 x 100 Watts at 8Ω, 2 x 150 Watts at 4Ω
- > For mono applications, a Bridge mode links both channels of the amplifiers, thus providing even more power, with a power rating of 300 watts driving an 8 Ohm load.
- > Clean, crisp sound - Impressive audio specifications such as 0.04% THD, dynamic range of 105 dB, crosstalk of 80 dB, and frequency response of 10 Hz to 55 kHz guarantee ultra-clean sound quality.
- > Independent input level controls for each channel allow precision adjustments.

continues»

FRONT PANEL

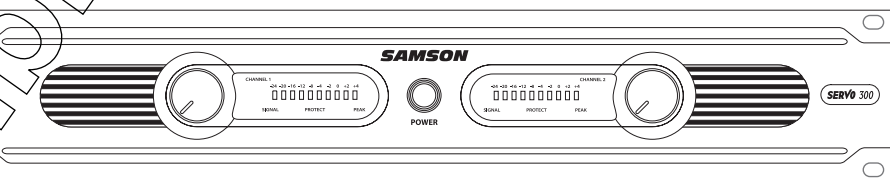

BACK PANEL

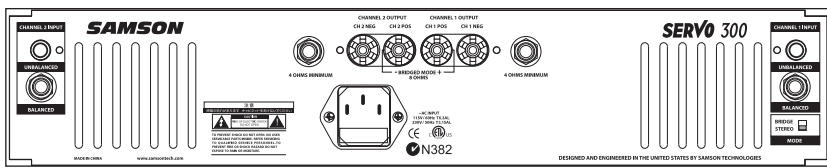

**PRODUCT SPECIFICATION SHEET**



SERIES  
**SERVO 300**

DESCRIPTION  
**POWER AMPLIFIER**

CATEGORY  
**AMPLIFIERS**

**FEATURES (continued)**

- > 10 segment LED signal indicators for each channel continuously display power output levels and allow you to correct for overloading (clipping) conditions.
- > Unique stable bipolar circuit design that continuously keeps DC output during idling at or near zero volts (thus keeping idle speakers at their zero point). This serves to minimize heat overload problems by effectively preventing the Servo Series from applying power when unnecessary.
- > Forced air cooling via two temperature-sensitive, variable speed fans provides reliable performance without thermal and overheating problems.
- > Protection relay circuitry (with dedicated LEDs for each channel) that guards against overheating or faulty wiring conditions and also prevents "thumps" when powering on or off. This means that you can use the Servo 300 with a single power strip into which a mixer or other audio devices are connected, without danger of damage to connected speakers.
- > Input connectors for each channel accommodate both RCA or balanced 1/4-inch TRS plugs.
- > Output connections are made via 5-way binding posts.
- > Toroidal transformer power supply for high current and low profile.
- > The Servo 300 can be mounted in any standard 19" rack (taking just two rack spaces), making it easy to integrate the amp into any fixed or traveling PA rig.
- > Rugged construction (an all-steel chassis with a cool gray finish and a lightweight anodized aluminum heat sink) makes the Servo 300 eminently roadworthy.
- > Extended three-year warranty.

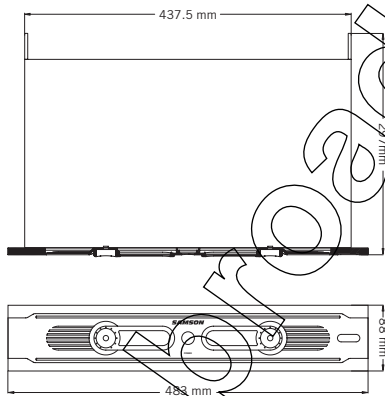

**ARCHITECT'S & ENGINEER'S SPECIFICATIONS**

The Samson Servo 300 shall be a two space rackmount stereo power amplifier. It shall deliver 150 watts per channel at 4 Ohms or 300 watts into 8 Ohms in bridge mono mode. It shall have 1/4 inch balanced inputs and RCA unbalanced inputs. It shall be a bi-polar design and use a toroidal transformer. The front panel shall have volume controls and LED metering for each channel. The rear panel shall also have 5 way binding posts for the amplifier outputs.

**SERVO 300 SPECIFICATIONS**

<b>Stereo both channel driven</b>	
8 Ohms.....	100 Watts x 2
4 Ohms.....	150 Watts x 2
<b>Bridged mono</b>	
8 Ohms.....	300 Watts
<b>Signal to Noise Ratio (20Hz-20k) .....</b>	
	102dB
<b>Distortion (SMPTE-IM) .....</b>	
	0.01%
<b>Input sensitivity @8 Ohms .....</b>	
	1.24V(4dBu)
<b>Voltage Gain .....</b>	
	33dB
<b>Output Circuitry Class .....</b>	
	AB
<b>AC Power</b>	
@1/8 rated power 4 Ohms, max. ....	0.7A
@1/3 rated power 4 Ohms, max. ....	1.7A
@ rated power 4 Ohms, max. ....	5.0A
<b>Distortion (typical @4 Ohms)</b>	
20Hz-20kHz,10dB	
below rated power .....	0.01%
1kHz, rated power .....	0.1%
<b>Frequency Response</b>	
@8 Ohms 1Watt, 20Hz-20kHz .....	+0/-0.5dB
<b>Damping Factor (400Hz) .....</b>	
	280
<b>Input Impedance .....</b>	
	15k Ohm Unbalanced, 30k Ohm Balanced
<b>Input Clipping .....</b>	
	10Vrms (22dBu)
<b>Cooling .....</b>	
	Continuously variable speed, fan forced air
<b>Connectors (each channel)</b>	
Input .....	RCA unbalanced and 1/4"(6.3mm) TRS, balanced
Output .....	5-way Binding post and 1/4" Phone
<b>Controls .....</b>	
	AC power switch, Channel 1 and 2 volume
<b>Indicators .....</b>	
	Power on (blue), Protection (amber), Signal (green) for each Ch., Peak(red) for each Ch. Level: , -24 dB, -20 dB, -16 dB, -12 dB, -8 dB, -4 dB, -2 dB, 0, +2 dB and +4 dB (PEAK).
<b>Protection .....</b>	
	Short circuit,Thermal,Current limit,DC offset,Current inrush, RF protection, Turn on/Turn off muting
<b>Power Requirements .....</b>	
	115/230,240VAC,50/60Hz
<b>Dimensions (W x H x D) .....</b>	
	19" x 3.5" x 11.7" (483mm x 89mm x 297mm)
<b>Net Weight .....</b>	
	20 lbs (9.09 kg)