



PRODUCT
C01U

DESCRIPTION
USB STUDIO CONDENSER MICROPHONE

SERIES
USB MICROPHONES

CATEGORY
USB CONDENSER



GENERAL DESCRIPTION

The C01U features a large, 19mm ultra thin diaphragm capsule with an onboard high quality Analog-to-Digital converter and USB output. The C01U is perfect for recording your music, or any acoustic audio source on your favorite DAW (Digital Audio Workstation).

Just plug in the supplied USB cable, launch your DAW and start recording. For expanded control, install the Samson Softpre C01U driver software and you'll have additional features like programmable GAIN, Low Cut Filter, Input Metering and Phase switch.

The C01U faithfully reproduces a variety of sound sources including vocals, acoustic instruments and overhead cymbals, to name a few. The extended frequency and fast transient response insures an accurate reproduction with linear characteristics from bottom to top.

FEATURES

- > Large Diaphragm, 19mm, Studio Condenser with USB Digital Output.
- > Compatible with any computer based Digital Audio Workstation.
- > The extremely detailed sound reproduction makes it ideal for recording vocals, acoustic instruments and just about any other sound source.
- > High Quality AD converter with 16 Bit, 48K sampling rate.

- > Downloadable Software applet for MAC and PC provide additional features like Programmable Gain, LED Input Metering, Low Cut Filter, and Phase.
- > 19mm Capsule with 3-micron Diaphragm.
- > Hyper Cardioid pick-up pattern.
- > Solid Die Cast construction.
- > Swivel Stand Mount and 10 foot USB cable included.

ARCHITECT'S & ENGINEER'S SPECIFICATIONS

The Samson C01U, USB condenser microphone shall be a USB output microphone. It shall have a 19mm diaphragm. It shall have an analog to digital converter built in. The output shall be of the USB type at 16 bit, 48kHz, meant to be plugged directly into the USB port on a computer. The Samson C01U shall get the power for the condenser element and A to D circuitry directly from the computers USB port. A USB cable shall be supplied with the microphone.

C01U SPECIFICATIONS

Frequency Response	20~18000 HZ
Polar pattern	Hyper- cardioid
Element type	Electret condenser type
Diaphragm thickness	3 microns
SPL	136 dB Max.
Dimensions Height (H x W x D)	7" x 2.125" x 2.125" (180mm x 54mm x 54mm)
Weight	1.06 lbs. (.48 kg)
Shipping Weight	2.5 lbs.(1.15 Kg)

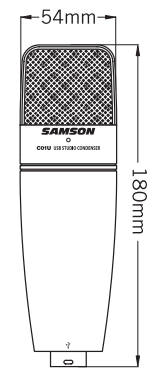

PRODUCT SPECIFICATION SHEET

SERIES
USB MICROPHONES

DESCRIPTION
USB STUDIO CONDENSER MICROPHONE

CATEGORY
USB CONDENSER



C01U FREQUENCY RESPONSE

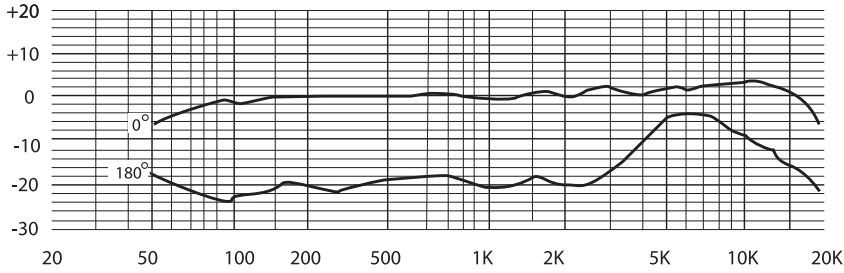

C01U POLAR PATTERN

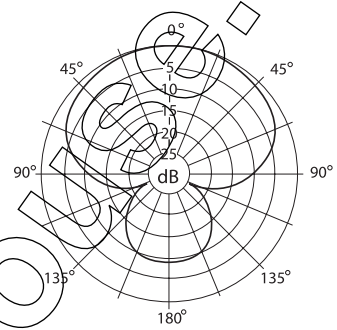

www.broadcastwarehouse.com