

STAND-ALONE DIGITAL STEREO GENERATOR



It's inconvenient to go to the transmitter every time your station's audio processing needs adjustment. Break free of transmitter site tyranny with Omnia.sg, the stand-alone, high-performance digital stereo generator that gives FM broadcasters complete freedom in locating their audio processing equipment.

Omnia.sg is designed to complement your existing audio processing. Using the same proven stereo generation technology used in Omnia audio processors, Omnia.sg provides the stereo generator function as well as a selectable composite clipper and baseband filter for crisp, clean loudness. It's the best of both worlds: clear, digital stereo generation, and the convenience of locating your processing conveniently at the studio.

The Omnia.sg accepts both analog and digital inputs to accommodate various types of studio-to-transmitter (STL) links; dual composite outputs are provided, along with SCA loop-throughs. A simple front panel interface makes set-up and calibration simple, and a lock-out function prevents inadvertent changes. LED monitoring of input and output levels is complemented by a BNC composite monitor point on the front panel for ease in testing. Status LEDs on the front panel include a silence detector and general failure warning, and a rear panel connector provides status outputs and remote control outputs.

Omnia.sg. Complete control is yours . . . at last.

OMNIA.SG BLOCK DIAGRAM

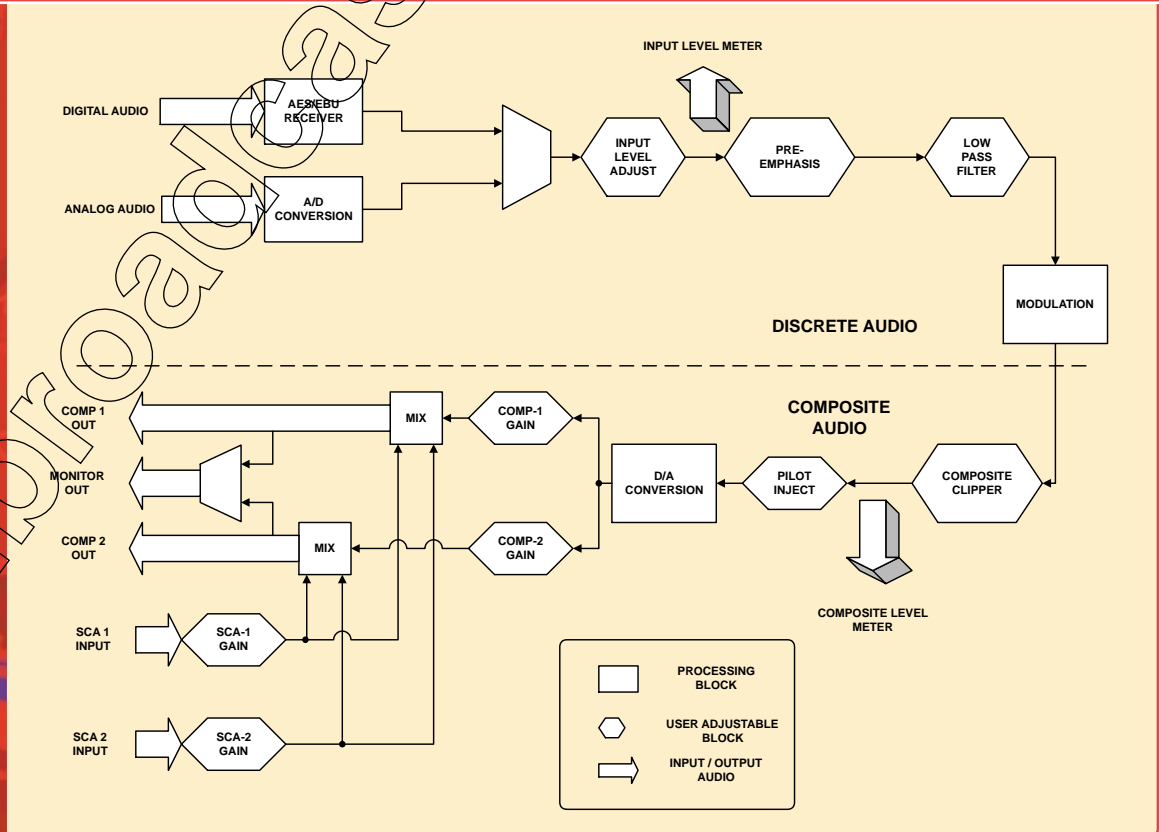

STAND-ALONE DIGITAL STEREO GENERATOR

Performance

All measurements referenced to 100% modulation unless otherwise noted.

SNR: >90 dB

Distortion: <0.02%

Spectrum: 60–100 kHz, <–75 dB

Crosstalk: <–75 dB

Separation: >60 dB, 20 Hz–15 kHz, 38 kHz
Subcarrier suppression: <–85 dB
Pilot accuracy: ±0.5 Hz

Installation

Analog Inputs:

Left/right balanced, XLR (female) type connectors, 10 kohm impedance

AES/EBU Input:

XLR (female) type connector
Sample rate 32–48 kHz, sample rate converted to 48 kHz

SCA Inputs:

BNC type connector, unbalanced
5 kohm impedance, jumper to 75 ohm, gain adjust +6 dB to 12 dB

Composite Baseband Output:

Two (2) BNC type, unbalanced
Independent level control, source impedance 10/75 ohm selectable
Output level adjustable to 23.5 Vpp

Pilot Reference Output:

BNC type connector, unbalanced
TTL level output square wave (0 – + 5V)

Front Panel Composite Monitor:

BNC type connector, unbalanced
Selectable for COMP 1 or COMP 2 monitoring
Buffered duplicate of back panel signals

Power Interface

110–240 VAC 3-terminal plug
Switch-mode power supply

Adjustments/Indicators

Front Panel Adjustments:

- Lock Mode protects accidental front panel adjustments
- **Input Level:** –10 dB to +12 dB (0.2 dB step), software controlled
- **Composite Clip Drive:** +0 to +3.0 dB (0.1 dB step), software controlled
- **Pilot Injection Level:** OFF, 6% to 12%, software controlled
- **Phase Adjust:** –32 to +32 degrees
- Analog/Digital Input select
- Mono/Stereo operation
- Pre-emphasis Off/50µS/75µS select
- 15 kHz low-pass filter On/Off select
- Separate Level Control for Composite Output 1 and 2 (screw pot)
- Separate Level Control for SCA Input 1 and 2 (screw pot)
- Monitor Selector COMP 1/COMP 2

Front Panel Indicators:

- Silence detect LED, 8 seconds of no input level
- Failure LED, 8 seconds of no output level
- AES/EBU Error LED, immediately upon loss of valid AES/EBU bitstream
- Left/Right level indicators, 8-segment LED bargraph
- Composite Output indicator, 8-segment LED bargraph, shows depth of composite clipping

Remote Control Interface:

- DB15 female shielded connector
- 3 momentary close-to-ground inputs
- Analog/Digital Input select
- Pre-emphasis On/Off
- Mono/Stereo operation
- 1 static close-to-ground input
- Force Analog mode (unit returns to previously selected input when released)
- 3 pairs of dry relay status outputs
- Silence Detect and Failure Detect (same as on front panel)
- AES/EBU Error Detect (same as on front panel)
- Analog operation selected
- 3 open collector status inputs (each requires a separate current limiting resistor when used to power LED indicators)
- Mono operation selected
- Pre-emphasis On selected

Software Field Upgradable

Back panel RS232 interface allows software upgrade with terminal program
Shielded DB9 female connector



2101 Superior Avenue, Cleveland, Ohio 44114—USA

Tel: +1 (216) 241-3343 Fax: +1 (216) 241-4103

E-Mail: info@nogrunge.com • www.nogrunge.com

Omnia Europe Johannistr.6 D85354 Freising—GERMANY

Tel: +49.8161.42467 Fax: +49.8161.42402

E-Mail: europe@nogrunge.com • www.nogrunge.com

© Copyright 2000 TLS Corporation. Features and specifications are subject to improvement or change without notice.
Telos Systems, the Telos logo, are trademarks of TLS Corporation. All other trademarks are the property of their respective holders.