



PR 35

Dynamic Microphone



- Largest dynamic element available
- Smooth response sounding like a ribbon
- Wide frequency response.
- Articulate natural mid range
- Perfect for broadcast studios
- Properly positioned hum bucking coil and heavy steel case insure maximum shielding
- Assembled and tested in Illinois

General Description:

The Heil PR 35 represents completely new dynamic microphone technology designed for a wide range of professional applications such as sophisticated recording, live sound, and commercial broadcast. Its smooth, wide frequency range sounds like a ribbon but can withstand large amounts of SPL. Outperforming the tired, 30 year old technology of the industry, the large diameter of the PR 35's dynamic element produces an outstanding upper mid range that makes the PR 35 ideal for drum micing, guitar amp micing, instrument micing and vocal micing.

Since 1982, Heil Sound has been the leading manufacturer of communications microphones and has a paramount understanding of phasing. When properly applied, this knowledge creates outstanding cardioid patterns with unbelievable rear rejection that removes unwanted sounds that try to enter from the off axis rear. The pattern control of the Heil PR 35 is outstanding. This exceptional performance is achieved by using the ideal combination of materials for the large low mass diaphragm and a special mixture of neodymium, iron, and boron that gives the PR 35 the strongest magnet structure available. These features allow the microphone to achieve magnificent dynamic range.

Frequency response	40 Hz - 18 kHz
Polar pattern	super cardioid
Impedance	600 ohm balanced
Output level	-52.9 dB
End fire generating element	1 1/2" diameter dynamic
Polarity	pin 2+
Magnet structure	neodymium, iron & boron
Case structure	steel
Dimensions	
Length	7.67"
Diameter	1.97"
Stem diameter	.98"
Weight	10.5 oz
Finish	black rubberized
Furnished Accessories	SM-5 mic clip and aluminum carrying case
Optional Accessories	PL 2T and SB-2

The large diameter dynamic element is mounted in a unique sorbothane shock mount atop a non-resonant fixture, decoupling the element from the massive steel body. This body and the internal hum bucking coil removes any worry of using the PR 35 near monitor screens or noisy lighting fixtures and controls. The new technology of the Heil PR 35 has redefined the dynamic microphone with superior wide frequency response, the lowest presence of noise in the industry, flawless design, and elite quality expected by an innovator and leader in the field. Your ribbon microphones will now be jealous.

Dimension Drawing:

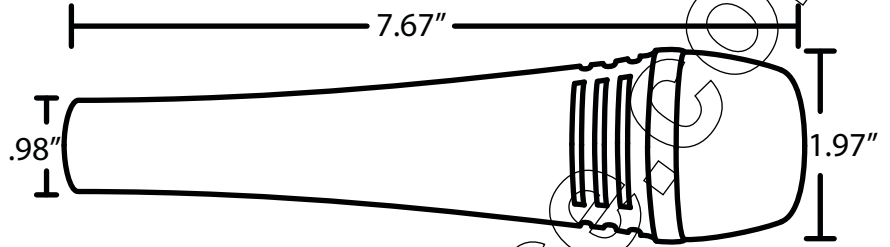

Engineers' Specifications:

A high performance microphone shall bring new large diameter technology to the industry. It shall have a personality in it's wide frequency response of 40 Hz. to 18 kHz. at the -3 dB points. The traditional Heil Sound 'bouquet' of mid range articulation will be featured which will bring gorgeous speech and instrument reproduction without the use of outboard equalization. A high degree of phasing plug assembly shall reduce the rear rejection typically at -18 dB or better. A large 1 1/2" diameter low mass voice coil assembly with a specially treated diaphragm that can create large dynamic levels. A special blend of neodymium, iron and boron will produce the strongest of magnet structure for this high performance microphone. Nominal impedance shall be 600 ohms. The proximity effect which is present in all cardioid microphones will be properly eliminated in the design of this new microphone. The response will be smooth and resonant. Ideal for guitar amplification, vocals and drum micing. There shall be a hum bucking coil to eliminate hum and noise when used near a cathode ray tube monitor or around high EMF levels. The case will be created in steel, finished in a rubberized, matte black. An aluminum case and SM-5 mic clip will be supplied. The new dynamic technology from Heil Sound shall be named the PR 35.

Wiring Diagram:

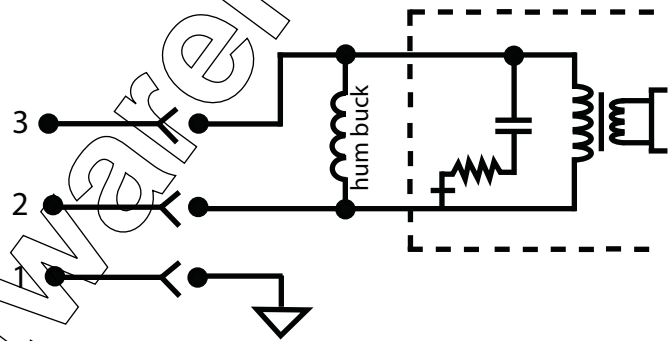

Frequency Response:

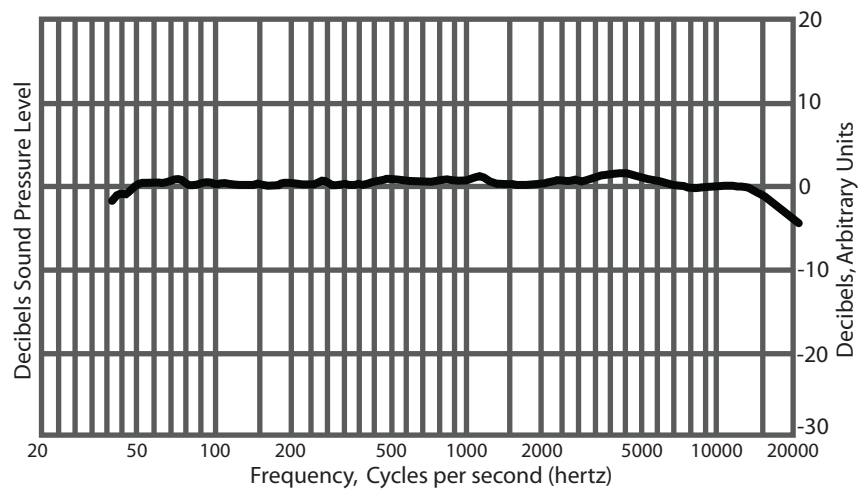

Heil Sound Ltd.
5800 North Illinois
Fairview Heights, IL 62208
618-257-3000 618-257-3001 fax
www.heilsound.com



For information contact
info@heilsound.com
For orders contact
orders@heilsound.com
For technical support contact
618-257-3000