

Lyra

DR

Desktop digital On-Air mixer

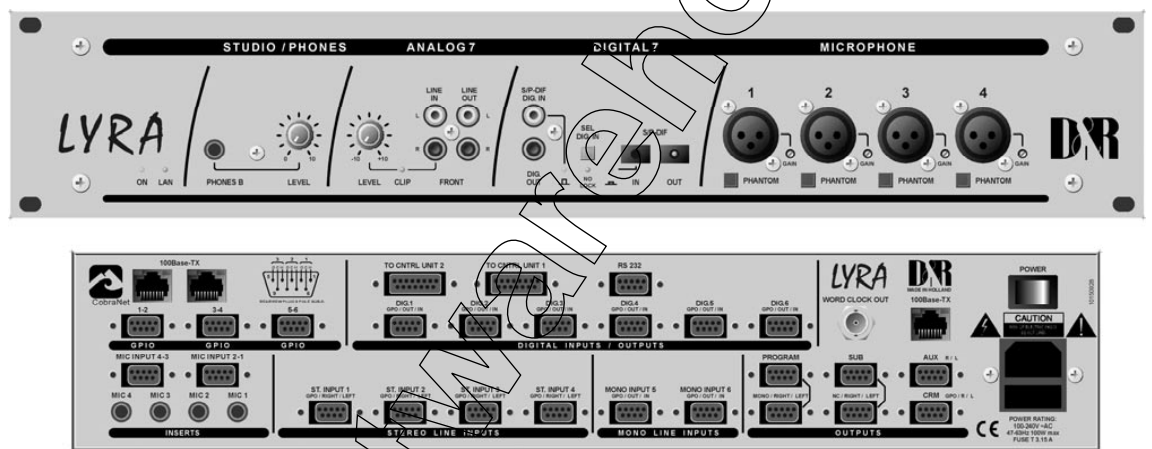

I/O RACK FRONT AND BACK VIEW



EIGHT FADER CONTROL SURFACE

Lyra

compact universal digital desktop mixer



System overview

The Lyra is a fully digital desktop mixer. Its concept originates from the latest technologies which are brought to a 'easy to use' and 'versatile' mixer.

The Lyra is based on two sophisticated system parts: a huge matrix/router and powerful DSP power. The balanced combination makes the Lyra a flexible and powerful audio-tool.

Added values to this clever digital machine are the options to control and administrate the device from any location. Its made that easy for you, simply use your internet browser for remote service.

Also you have a grow path towards audio-networking. The Lyra has an option to add Cobranet to enlarge your audio matrix. This option makes sure you are compatible with many other audio manufacturers to receive, transmit and share audio from different locations in your LAN.

This all you can find in a very compact 2HE rack unit. The huge possibilities can be controlled from an easy to understand 4 fader desktop control surface. A second 4 fader surface can be connected to have 8 stereo modules.

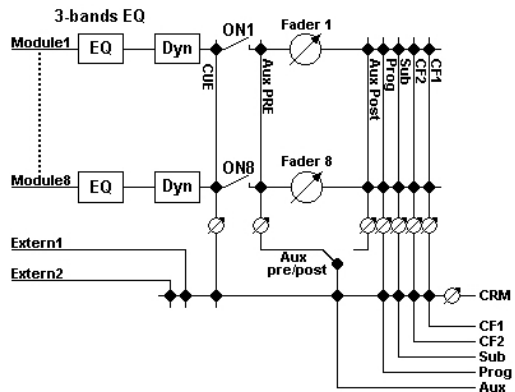

Routing & Mixing

The Lyra has an huge matrix onboard, 34 Inputs to 25 Outputs (& 5 fixed buss outputs). You can configure the matrix the way you want by the web server. Added to the matrix are 8 outputs to the DSP/mixer and 10 outputs from the DSP/Mixer. That makes it possible to add processing functionality to your matrix to create your own mixer.

The DSP/Mixer contains 8 stereo modules. Each module can adjust gain, 3 band EQ, 1 knobs compressor after processing you can send the signal to the busses Prog, Sub, Aux, Cleanfeed 1 and Cleanfeed 2. Each buss has a fixed analog output.

This short description makes clear you have a complete 8 module broadcast mixer in this compact box.

Audio Networking

Lyra the possibility to be part in the audio network. From that moment you can share your audio and take audio from many different locations. Even your network administrator can now track all devices by using the remote control over Ethernet (TCP/IP).



Remote Control

The wishes you always had now become reality, Its possible to remote service and/or control the Lyra. Just from your lazy chair you can login to the Lyra web-server, check settings and the log.

Further you can access the FTP server to transfer presets and or update firmware. That makes live easy!

There is even a possibility to control your audio from remote locations by using a TCP/IP connection. The ActiveX control which is part of the package makes it possible to write your own program, do scheduling or make scripts to control the Lyra.

Easy to use

You will be surprised how intuitive the Lyra will be in use. Even a high technology digital product can be easy to understand ! All different parts of the Lyra are designed to be clear in layout and functions. Within a few minutes you know how to work with this flexible equipment.

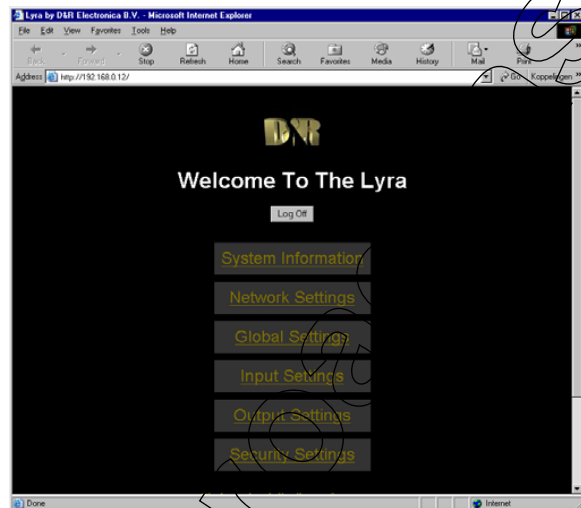

On Air

Its already clear the Lyra is a versatile device. Without any concession you can use the Lyra if a 8 channel on-air console instead of doing desktop production work.

The surface layout and Lyra settings are very familiar for broadcast engineers. The amount of GPIOs shows you can do hardly any trick you want !

The simplicity of the software and possibilities of integrating your software/automation with the ActiveX control, that's something you have to check yourself....

D&R Electronica Weesp B.V.
Rijksweg 15B
1382 GS Weesp
The Netherlands



Phone: +31 - 294 - 418014
Fax: +31 - 294 - 416987
email: info@d-r.nl
website: www.d-r.nl