

Distribution Amplifiers 1133 1485 1622

Description

The 1133 and 1485 are resistively split, stereo distribution amplifiers. The 1133 has six stereo outputs and the 1485 is a ten stereo output version. The 1622 is a seven stereo output electronically balanced distribution amplifier. All of the amplifiers are based on a 220mm Eurocard to enable several distribution amplifiers to be mounted in a standard 3U, 19" rackmounted card frame.

Features:

1133 + 1485: Two electronically balanced, high impedance inputs, which can be operated in stereo or dual mono mode. As the stereo input has the facility to be monoed it is possible to configure the unit as dual input mixed to twelve (1133) or twenty (1485) mono outputs. Input transformers are available as an optional extra. There is also the provision for 600 ohm termination loads. Each input has an independent gain preset to give 9dB of adjustment.

1622: Two electronically balanced, high impedance inputs. Input transformers are available as an optional extra.

1133: Twelve electronically balanced, resistively split outputs for driving balanced circuits.

1485: Twenty electronically balanced, resistively split outputs for driving balanced circuits.

1622: Seven electronically balanced low impedance stereo outputs, one of which can be monoed with an on-board header. Both A and B legs of each stereo output have independent gain adjustment of 6dB. The gain-adjustment potentiometers are located at the outside edge of the card for easy access during line-up. The outputs will drive both balanced and unbalanced circuits without affecting the gain of other outputs.

Connectors

1133: All audio inputs, audio outputs and power via a 32 way DIN 41612 connector.

1485 & 1622: All audio inputs outputs and power via a 64 way DIN 41612 connector.

Options – Transformer balanced inputs.

Applications

The 1133 and 1485 Eurocards enable the user to incorporate a distribution amplifier in existing equipment or card frames. For equipment bays and audio control room applications its high packing density gives up to twenty four amplifiers (12 stereo amplifier cards) can be housed in a 3U card frame.

The 1622 Eurocard enables the user to incorporate a distribution amplifier in existing equipment or card frames. For equipment bays and audio control room applications twenty four amplifiers (12 stereo amplifier cards) can be housed in a 3U card frame.

Pre Assembled Systems

A maximum of twelve 1133 distribution amplifiers can be supplied pre wired in a 3U, 19" rackmount card frame with an integral modular power supply. All audio inputs and outputs are pre-wired to 56 way Varicon connectors.

N.B. Please note that the 1485 requires a different card frame to the 1133. However, card frames can be custom-wired to accommodate both cards - please contact us for more details.

A maximum of twelve 1622 distribution amplifiers can be supplied pre-wired in a 3U, 19" rackmount card frame with an integral modular power supply. All audio inputs and outputs pre-wired to 56 way Varicon connectors.

Key Features

1133

2 electronically balanced inputs

12 resistively split outputs

1485

2 electronically balanced inputs

20 resistively split outputs

1622

2 electronically balanced inputs

7 stereo electronically balanced outputs



AUDIONICS
professional broadcast equipment

**31 JESSOPS RIVERSIDE
SHEFFIELD
S9 2RX
ENGLAND
TEL +44 (0)114 242 2333
FAX +44 (0)114 243 3913
email info@audionics.co.uk
Web www.audionics.co.uk**

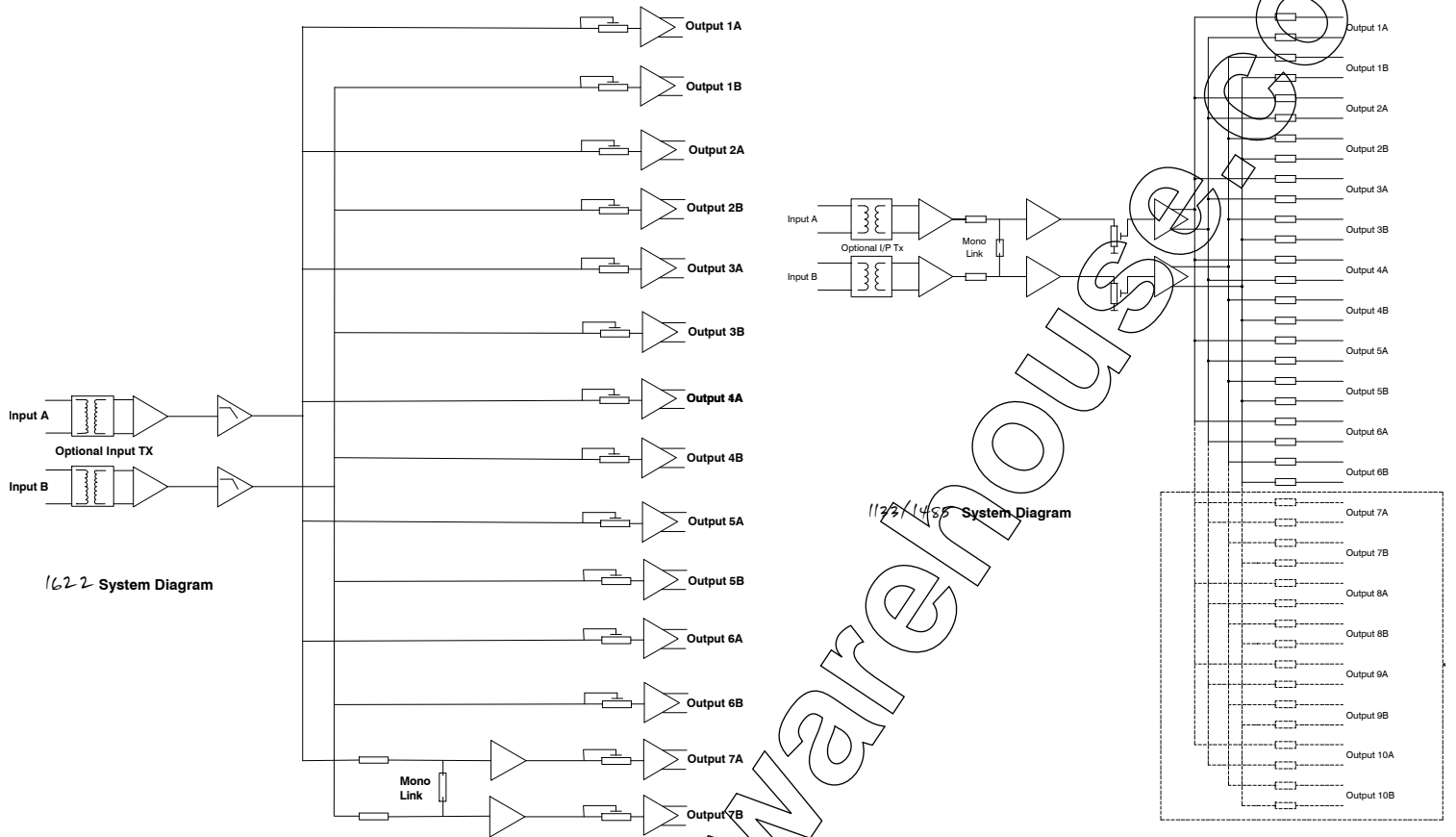

Technical Specifications	1133 & 1485	1622
Input Impedance	>50k ohms	36k ohms
Input Balance (Tx Opt)	<-50dB, 10kHz	-
Maximum Input	+22dBu	+22dBu
Output Impedance	45 ohms	50 ohms
Maximum Output	+24dBu	+24dBu
Output Gain Adjust	0dB	6dB
Frequency Response	0.5dB, 20Hz-20kHz (50kHz built in low pass filter)	0.5dB, 10Hz-24kHz
Distortion (THD + Noise)	<0.03%, 100Hz-10kHz @+20dBu	<0.01%, 100Hz-10kHz @+20dB
Noise	<-86dBu Peak, 20Hz-20kHz	<-80dBu peak, 20Hz-20kHz
Dimensions	160(220 opt.) x 100mm Eurocard	220mm x 100mm Eurocard
Connector	32/64 DIN 41612	64/96 DIN 41612
Power	15 to 18V, 100mA quiescent	15 to 18V, 100mA quiescent

Specification and designs are subject to change without prior notice for the purposes of improvement. E & OE