



ASI8702, ASI8712, ASI8722, ASI8723, ASI8724, ASI8725, ASI8732, ASI8733, ASI8734, ASI8735 FOUR/EIGHT CHANNEL TUNER ADAPTERS

DESCRIPTION

The ASI8700 series are professional PCI tuner adapters designed for use in radio and NTSC-TV broadcast audio monitoring and auditing.

Eight different channels can be received and recorded simultaneously from a single antenna input.



FEATURES

- Eight AM/FM tuners (ASI8702)
- Four AM/FM tuners (ASI8712)
- Six AM/FM and two NTSC-TV tuners (ASI8722)
- Eight NTSC-TV tuners (ASI8723)
- Four NTSC-TV (ASI8724)
- Four AM/FM and four NTSC-TV tuners (ASI8725)
- Six AM/FM and 2 PAL-TV tuners (ASI8732)
- Eight PAL-TV tuners (ASI8733)
- Four PAL-TV (ASI8734)
- 4 AM/FM and four PAL-TV tuners (ASI8735)
- Four/Eight PCM record streams (one for each tuner)
- FM stereo decoding
- Audio monitoring of all tuners simultaneously
- 8 to 48kHz sample rates
- Up to 8 cards in one system
- Windows 2000/XP/Server 2003/Vista and Linux software drivers available

ASI8702/8723/8733

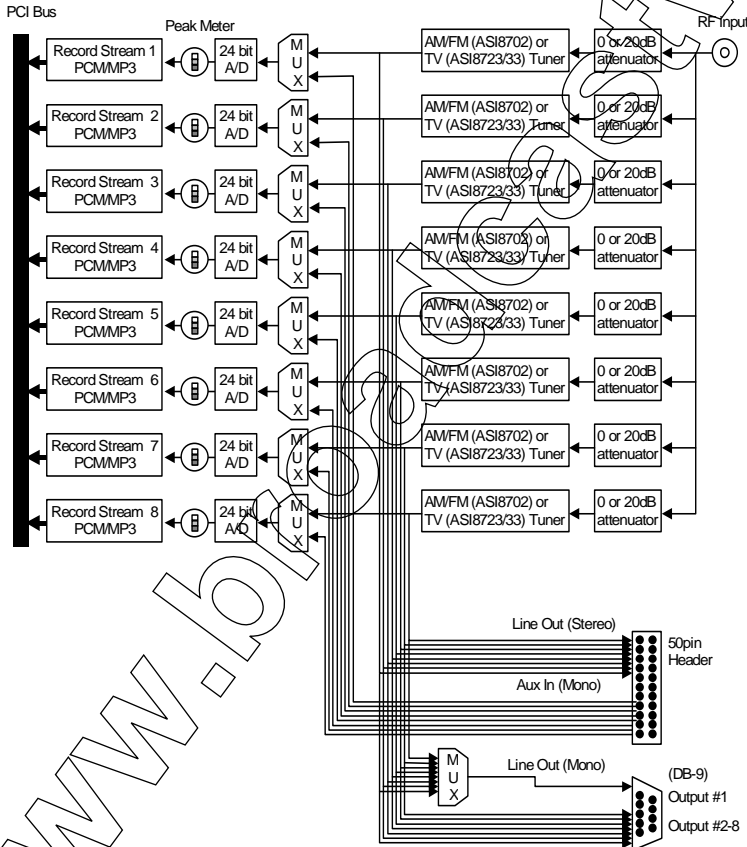

ASI8702 Connectors

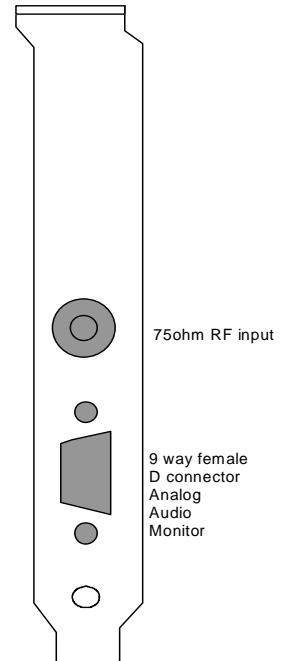

1 SPECIFICATIONS

RF INPUT

Connector F type 75 ohms
 Input Level -20dBmV minimum, +20dBmV Maximum
 Frequency Response 0dB +10/-0dB, 100kHz to 110MHz (F connector input to any tuner input)

AM/FM TUNER (ASI8702 only)

AM BAND

Frequency range 520kHz-1720kHz
 Sensitivity 20dBuV for 15dB S/N
 S/N 45dB @ 60dBuV RF Level, 1kHz sinewave, 75% modulation
 Audio bandwidth 4.1kHz

FM TUNER

Frequency range 75.9MHz - 108.1MHz
 Sensitivity 0dBuV for 30dB S/N
 S/N 62dB @ 60dBuV RF Level, 1kHz sinewave, 75kHz deviation
 Audio bandwidth 15kHz

NTSC-TV TUNER (ASI8723 only)

TV System M
 Frequency range 50.00MHz – 801.25MHz
 Sensitivity 0dBuV for 30dB S/N
 S/N 55dB @ 60dBuV RF Level, 1kHz sinewave
 Audio bandwidth 40Hz - 15kHz (+/-2dB)

PAL-TV TUNER (ASI8733 only)

TV System B,D,G,H,I,K
 Frequency range 48.25MHz – 863.25MHz
 Sensitivity 0dBuV for 30dB S/N
 S/N 55dB @ 60dBuV RF Level, 1kHz sinewave
 Audio bandwidth 40Hz - 15kHz (+/-2dB)

AUX LINE INPUT (MONO)

Connector 50pin 0.1" Header
 Level 4Vpp max

LINE OUTPUT

Connector DB-9 on bracket (Left channel only) and 50pin 0.1" Header (Stereo)
 Level 4Vpp max

SIGNAL PROCESSING

DSP Texas Instruments TMS320C6713@216MHz
 Memory 8MB
 Sample rates 8, 11.025, 12, 16, 22.05, 24, 32, 44.1, 48kHz
 Audio Formats 8 bit unsigned PCM
 16 bit signed PCM
 32 bit IEEE floating point PCM
 MPEG-1 Layer 3(MP3) [revH hardware and higher]
 MPEG Layer-3 audio coding technology licensed from Fraunhofer IIS and THOMSON multimedia)

BREAKOUT CABLES

CBL3002 (Included)

GENERAL

Bus Universal 32bit PCI (3.3V or 5V signaling)
 Dimensions PCI form factor - 13" x 4.5" x 0.8" (330mm x 115mm x 20mm) (excluding edge connector)
 Weight <TBD> max
 Operating Temperature 0°C to 60°C
 Power Requirements
 ASI8702: +5V @ 500mA, +3.3V @ 1.5A, +12V @ 1A, -12V @ 10mA
 ASI8723, ASI8733: +5V @ 2A, +3.3V @ 1.5A, +12V @ 500mA, -12V @ 10mA
 ASI8712: +5V @ 250mA, +3.3V @ 1.5A, +12V @ 500mA, -12V @ 10mA
 ASI8724, ASI8734: +5V @ 1.2A, +3.3V @ 1.5A, +12V @ 200mA, -12V @ 10mA

2 CONNECTORS

2.1 DB-9

The DB-9 connector makes available the left channel of each tuner output. Ch1 is sourced from a software-controlled mux and may be programmed to output Ch1... 8. The output level is 2Vpp into 10Kohms.

Monitor - 9pin female D

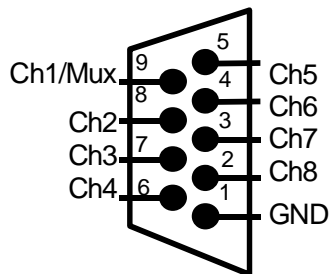

2.2 50pin Header

50 pin audio header is two rows by 25 pins with 0.1" spacing. It makes available the stereo outputs of each tuner and 8 auxiliary inputs (AUXIN0...7). The input and output signal level is 4Vpp max.



Pin 1

Signal	Pin #	Pin #	Signal
CH1L	1	2	GND
CH1R	3	4	GND
CH2L	5	6	GND
CH2R	7	8	GND
CH3L	9	10	GND
CH3R	11	12	GND
CH4L	13	14	GND
CH4R	15	16	GND
CH5L	17	18	GND
CH5R	19	20	GND
CH6L	21	22	GND
CH6R	23	24	GND
CH7L	25	26	GND
CH7R	27	28	GND
CH8L	29	30	GND
CH8R	31	32	GND
AUXIN1	33	34	GND
AUXIN2	35	36	GND
AUXIN3	37	38	GND
AUXIN4	39	40	GND
AUXIN5	41	42	GND
AUXIN6	43	44	GND
AUXIN7	45	46	GND
AUXIN8	47	48	GND
N.C.	49	50	GND

3 MIXER MAP

The mixer layout for the ASI8702 in Windows is as follows:

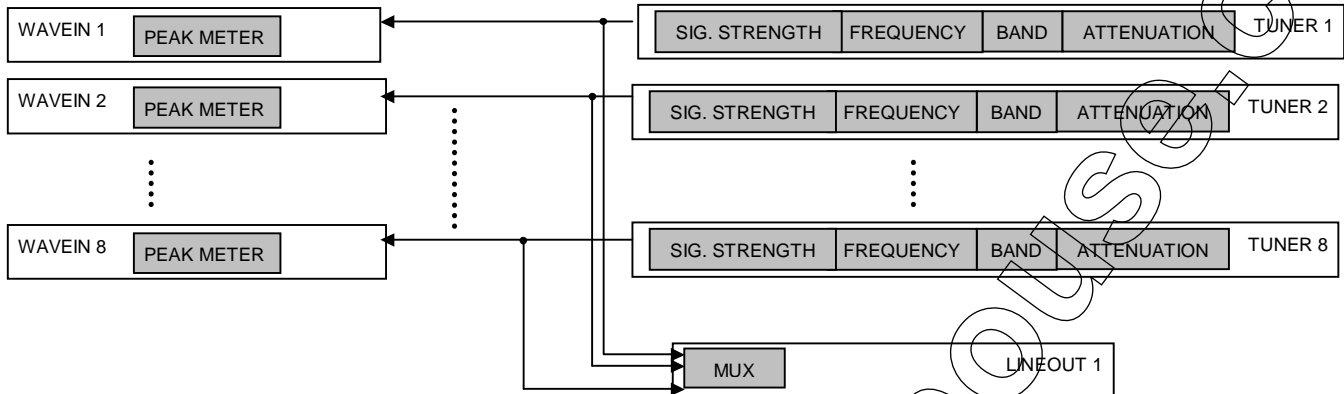

4 AUDIO FORMATS

The ASI8700 supports the following audio formats:

Format	HPI format	Windows format
8 bit unsigned PCM	HPI_FORMAT_PCM8_UNSIGNED	WAVE_FORMAT_PCM, wBitsPerSample=8
16 bit signed PCM	HPI_FORMAT_PCM16_SIGNED	WAVE_FORMAT_PCM, wBitsPerSample=16
32 bit floating point PCM (+/-1.0)	HPI_FORMAT_PCM32_FLOAT	WAVE_FORMAT_IEEE_FLOAT
MPEG-1 Layer 2	HPI_FORMAT_MPEG_L2	WAVE_FORMAT_MPEG -fwHeadLayer=ACM_MPEG_LAYER2 -fwHeadMode=ACM_MPEG_SINGLECHANNEL, ACM_MPEG_DUALCHANNEL, ACM_MPEG_STEREO
MPEG-1 Layer 3 (MP3) (revH h/w and higher)	HPI_FORMAT_MPEG_L3	WAVE_FORMAT_MPEG -fwHeadLayer=ACM_MPEG_LAYER3 -fwHeadMode=ACM_MPEG_SINGLECHANNEL, ACM_MPEG_DUALCHANNEL, ACM_MPEG_STEREO OR WAVE_FORMAT_MPEGLAYER3

Not all combinations of channels, samplerates and bitrates are allowed for MP3. The following table shows the supported variations, assuming all eight recording streams are being used:

Sample Rate (kHz)	Channels	Bitrates (kbs)
8, 11.025, 12	Mono/Stereo	16,32,40,48,56
16, 22.05, 24	Mono/Stereo	16,32,40,48,56,64,96,112,128
32	Mono only	32,40,48,56,64,80,96,112,128

5 TUNER

The ASI8702 has two AM/FM tuners and six TV/FM tuners. For each tuner the band, frequency and input/attenuation can be set, and the RF level can be monitored.

User

The tuner is controlled and monitored using the Tuner panel in ASIMIXER.EXE. The following sections explain the panel operation.



5.1 Gain

The Gain control switches an optional 20dB attenuator at the input to each tuner. Therefore the gain can be set to 0dB or -20dB.

User

The RF attenuator is switched on/off using the Gain slider on the Tuner panel.

Developer

Windows – use standard Windows control of type MIXERCONTROL_CONTROLTYPE_DECIBELS. Use MIXERCONTROLDETAILS_UNSIGNED to set or get control details. Units are in 10ths of a dB.

HPI – HPI_Tuner_SetGain()

5.2 Band

Set the band type to tune over. Possible bands are a subset of AM, TV, FM, FM-STEREO, TV NTSC-M, TV PAL-BG, TV PAL-BK, TV PAL-DK, TV SECAM-L, Aux Input. Within the FM band it is possible to select either mono or stereo.

User

The tuner band is selected using the tuner band dropdown.

Developer

Windows – use standard Windows control of type MIXERCONTROL_CONTROLTYPE_SINGLESELECT.

Use MIXERCONTROLDETAILS_LISTTEXT to retrieve the list of names and then MIXERCONTROLDETAILS_BOOLEAN to get or set the current selection.

HPI – Tuner band is selected using the HPI_Tuner_SetBand() API

5.3 RF Level

Each tuner can measure the RF level of the current channel. The level is returned in units of dBuV.

User

The RF level is displayed in the Rflevel section of the Tuner panel.

Developer

Windows – use standard Windows control of type MIXERCONTROL_CONTROLTYPE_SIGNED. This is a read-only control. Units are dBuV. Use MIXERCONTROLDETAILS_SIGNED structure for call to mixerGetControlDetails().

HPI – HPI_Tuner_GetRFLevel()

5.4 Frequency

Sets the radio frequency to which a tuner receives. The selected band determines the available range of frequencies, so band should be selected first. The frequency is expressed in kHz

AM range 520kHz to 1720kHz

FM range 87.9MHz to 107.9MHz

TV range 55.25MHz to 801.25MHz

User

Entering a number in the Freq edit box of the Tuner panel sets frequency.

Frequency must be specified in kilohertz (e.g. for 98.6MHz FM station, enter 98600).

Developer

Windows – use a standard Windows control of type MIXERCONTROL_CONTROLTYPE_UNSIGNED. Use MIXERCONTROLDETAILS_UNSIGNED structure for calls to set/get control details. Units are in kHz.

HPI – Tuner frequency is set using the HPI_Tuner_SetFrequency() API

5.5 FM De-emphasis

Sets the FM de-emphasis. Available in driver version 3.09.11 or later. Geographic regions around the world utilize differing de-emphasis settings. The USA uses 75 μ sec, while Europe uses 50 μ sec. This control allows the user to set the FM tuner de-emphasis. The default is 75 μ sec.

User

Select the de-emphasis setting in ASIControl.

ASIMixer does not show the FM de-emphasis.

Developer

Windows – not supported.

HPI – FM Tuner de-emphasis is set using the HPI_Tuner_FM_SetDeemphasis () API

6 ANALOG AUDIO MONITOR

The ASI8702 has a mono analog output on a D-9 female connector.

This output can be used to monitor the received audio from one of the eight tuners.

User

Select which tuner to monitor using the Mux section of the Line Out 1 panel

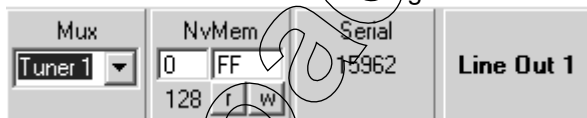

Developer

Windows – uses standard Windows control of type MIXERCONTROL_CONTROLTYPE_MUX. Use MIXERCONTROLDETAILS_LISTTEXT to retrieve the list of names and then MIXERCONTROLDETAILS_BOOLEAN to get or set the current selection.

HPI –

7 SAMPLE RATE CLOCK

The ASI8701 operates at a single sampling frequency. This is set by the first stream to start recording or playing. While any stream is active, the sample rate cannot be changed.

The sample rates that are supported are 16, 22.05, 24, 32, 44.1 and 48kHz.

8 CABLES

The ASI8702 comes with the CBL3002 DB9 to RCA breakout cable.

9 AM/FM FEEDS

There are two ways to feed both AM and FM signals to a single ASI87xx.

9.1 TV combiner/splitter

Mix the signals from an amplified FM antenna and an amplified AM antenna into one signal using a TV combiner/splitter. Feed the combined signal to the F connector on the ASI87xx.

9.2 Custom ASI87xx

Custom order an ASI87xx with separate AM antenna connectors for each AM tuner on the card.

10 PERFORMANCE

10.1 ASI8702 AM Performance

10.1.1 Bandwidth

Sweep signal is 1-15kHz sinewave modulated @ 75% on 620kHz with an RF level of 60dBuV

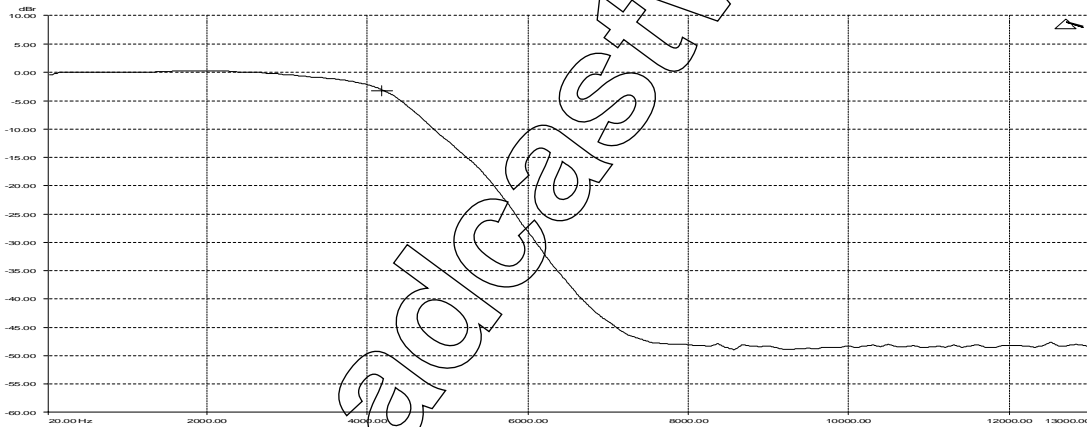

10.2 Sensitivity

Signal is mono 1kHz sinewave modulated @ 75% deviation on 620kHz

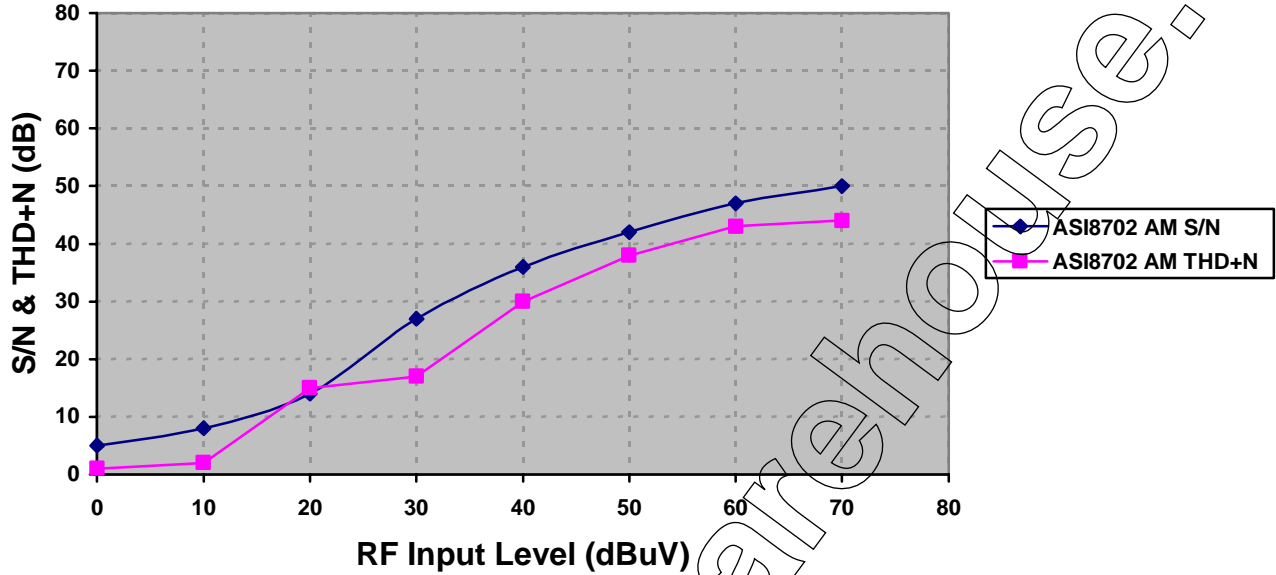

10.3 ASI8702 FM Performance

10.3.1 Sensitivity

Signal is mono 1kHz sinewave modulated @ 75kHz deviation on 90.1MHz

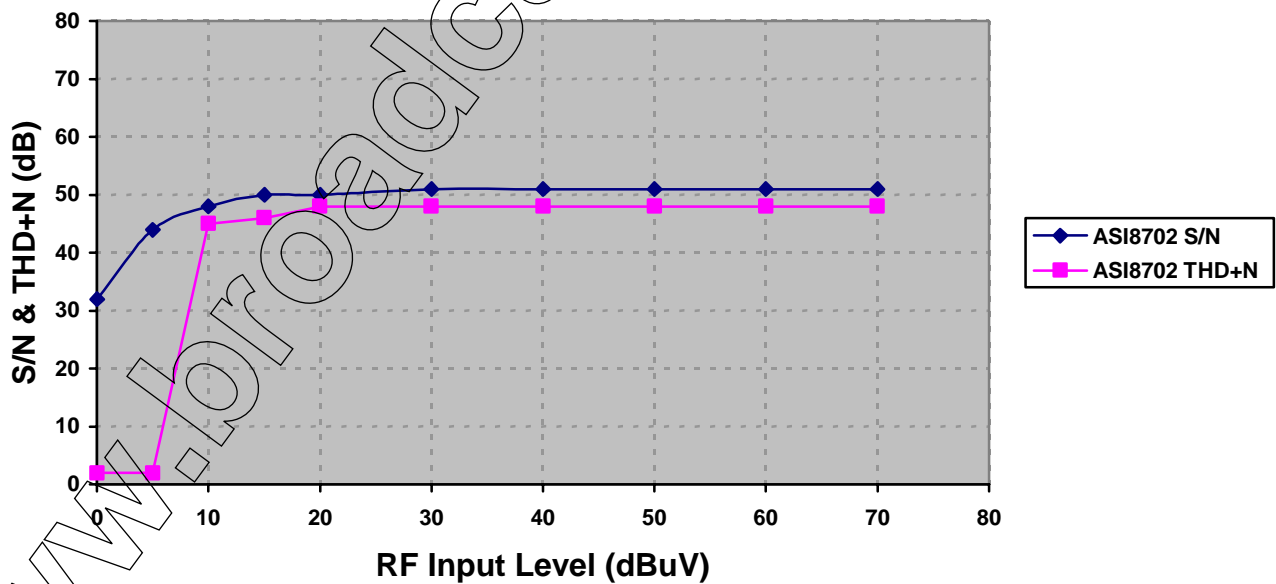

11 Cooling

The ASI87xx adapters can dissipate a significant amount of heat. AudioScience does control the deployment environment of the cards, but recommends:

- a) where possible there should be space between cards for improved airflow.
- b) additional cooling fan(s) should be added to the system enclosure if required.
- c) a fully populated system should be bench tested to check cooling operation.

12 REFERENCES

Specifications

SPCHPI.PDF - [Hardware Programming Interface \(HPI\) Specification](#)

SPCWAVX.PDF - [WavX - AudioScience Windows Multimedia Extensions](#)

All these documents are available from www.audioscience.com in the Technical Info section

[end]