

DESCRIPTION

The ASI5111 is a professional PCI audio adapter designed for use in radio broadcast production.

The adapter offers two stereo record stream from either a balanced analog input or AES/EBU digital input and four stereo play streams mixed to both a balanced analog output and an AES/EBU digital output.

Also included is a microphone input, with low noise pre-amp and a 48V phantom supply.



FEATURES

- Four stereo streams of PCM playback
- Two stereo streams of PCM record
- Balanced stereo analog input and output
- AES/EBU or S/PDIF digital input and output (software switchable).
- Low noise microphone input with 48V phantom supply and DSP based compressor/limiter and 3 band equaliser.
- 24bit analog-to-digital and digital-to-analog converters - 100dB SNR and 0.0025% THD+N.
- 11 to 96kHz sample rates.
- MRX™ multi rate mixing technology supports digital mixing of multiple sample rates.
- SoundGuard™ transient voltage suppression protects against lightning and other high voltage surges on all I/O
- Up to 8 cards in one system.
- Windows 98/NT/2000/XP and Linux software drivers available.

ASI5111 Connectors

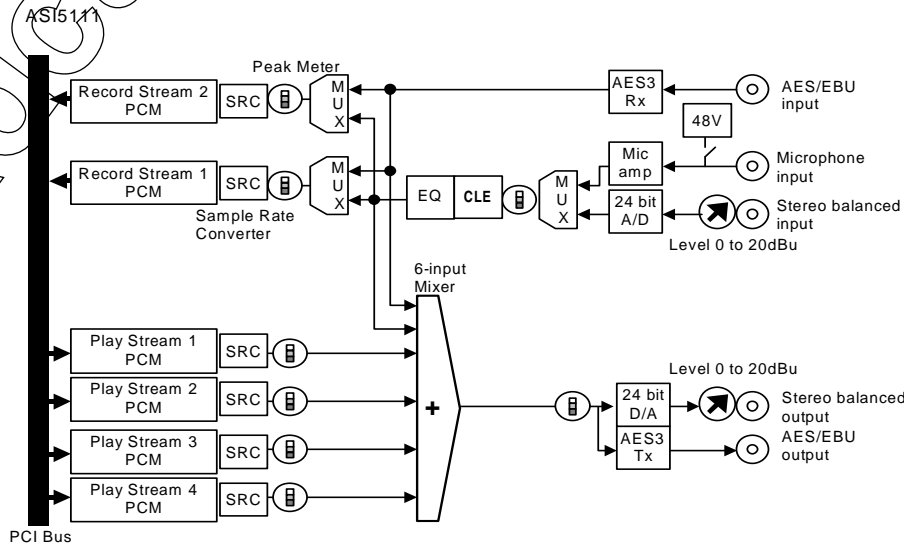
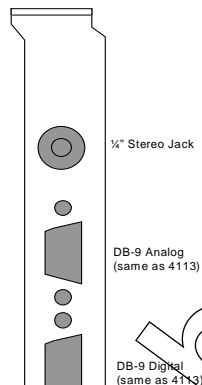

1 SPECIFICATIONS

BALANCED INPUT/OUTPUT

Connector	DB-9 Female
Input Level	-10 to +20dBu in 1dBu steps
Input Impedance	20K ohms
Output Level	-10 to +20dBu in 1dBu steps
Load Impedance	600ohms or greater
S/N Ratio ^[1]	> 100dB (record or play)
THD+N ^[2]	< 0.0025% (record or play)
Sample Precision	24bit Oversampling
Frequency Response	20Hz to 20kHz +/-0.25dB 20Hz to 40kHz +0.25/-5dB ^[3]

MICROPHONE INPUT

Connector	¼" TRS jack
Input Gain	20, 40 and 60dB software adjustable
Input Impedance	11K ohms (+ or - to ground)
Phantom Power	48V +/- 4V, software switchable on and off.
S/N Ratio ^[1]	90dB @ 40dB gain
THD+N ^[2]	0.005% @ 40dB gain
Frequency Response	20Hz to 20kHz +/-0.5dB 20Hz to 40kHz +0.5/-5dB ^[3]

DIGITAL INPUT/OUTPUT

Type	AES/EBU (EIAJ CP-340 Typel / IEC-958 Professional) S/PDIF (EIAJ CP-340 Typell / IEC-958 Consumer) (software selectable)
Connector	DB-9 Male
Sample Rates	32, 44.1, 48, 64, 88.2 and 96kHz
Sample Precision	24bit

SAMPLE RATE CLOCK

Internal	32, 44.1, 48, 64, 88.2 and 96kHz
AES/EBU In	32, 44.1, 48, 64, 88.2 and 96kHz

SIGNAL PROCESSING

DSP	Texas Instruments TMS320C6711@135MHz
Memory	8MB
Audio Formats	8 bit unsigned PCM 16bit signed PCM 32bit IEEE floating point PCM

BREAKOUT CABLES (INCLUDED)

Analog	CBL1001: DB-9 to 2 in and 2 out XLR
Digital	CBL1003: DB-9 to 1 in and 1 out XLR

GENERAL

Bus	Universal 32bit PCI (3.3V or 5V signaling)
Dimensions	PCI form factor – 6.75" x 3.9" x 0.6" (172mm x 100mm x 15mm)
Weight	8 oz (227g) max
Operating Temperature	0C to 70C
Power Requirements	+5V @ 600mA, +12V @ 150mA, -12V @ 70mA

[1] - S/N Ratio is the difference between a 1kHz digital fullscale sinewave and digital zero using an A weighting filter
 [2] - THD+N measured using a +20dBu 1kHz sinewave sampled at 48kHz and A weighting filter
 [3] - Using a 96kHz sampling rate

2 CONNECTORS

Analog DB9 (Female)

Digital DB9 (Male)

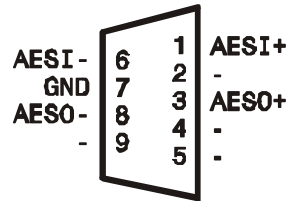
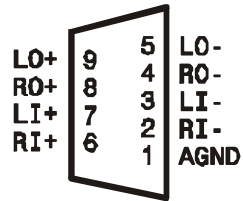

Microphone input jack – Tip=+, Ring=-, Shield=GND.

3 MIXER MAPS

3.1 HPI Mixer

The mixer layout for the ASI5111 as represented by the HPI is as follows. For details on each HPI control type, see the HPI specification (SPCHPI.PDF).

* SRC = Sample Rate Converter, not visible as an HPI object

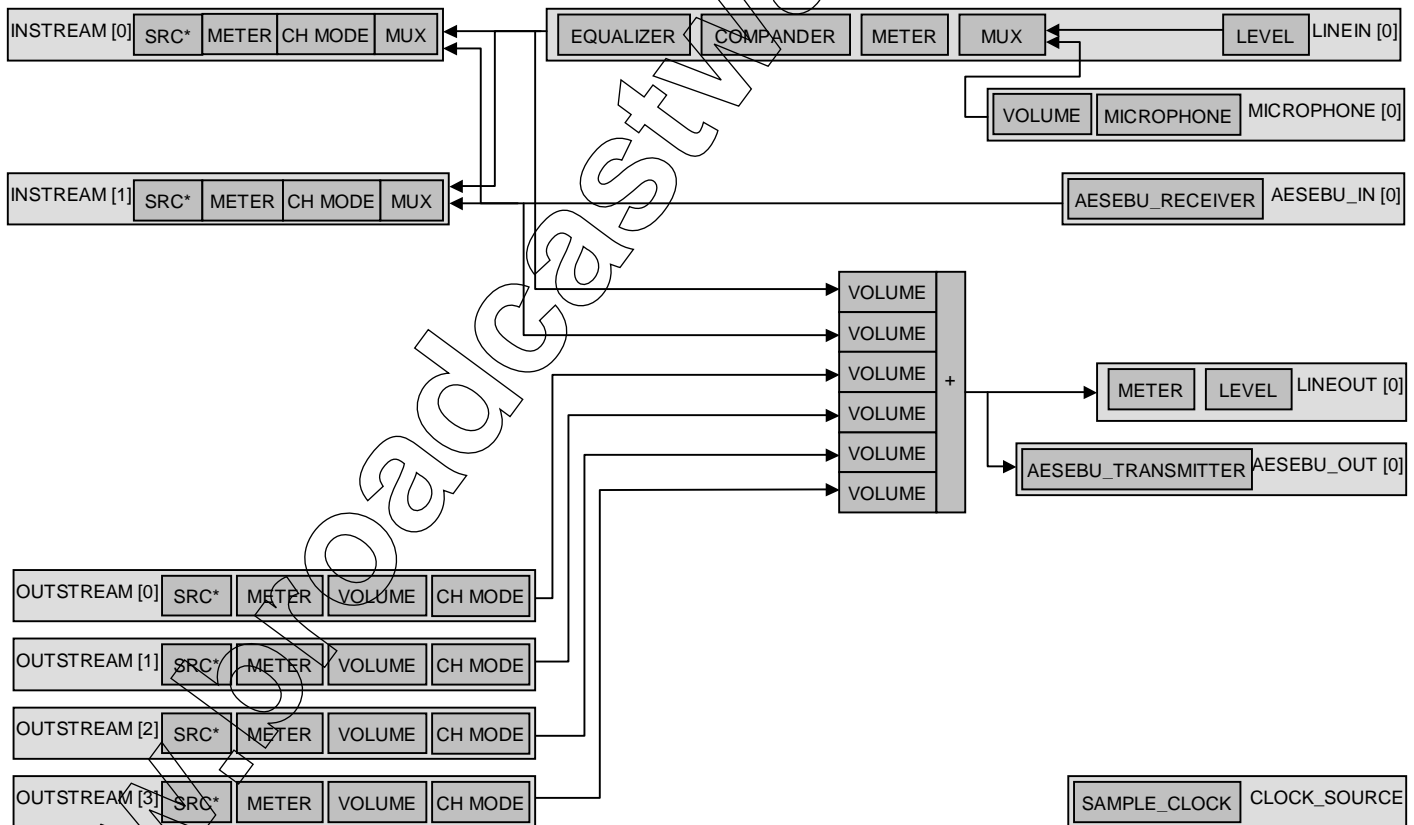

4 AUDIO FORMATS

The ASI5111 supports record and play of the following formats:

Format	HPI format	Windows format
8 bit unsigned PCM	HPI_FORMAT_PCM8_UNSIGNED	WAVE_FORMAT_PCM, wBitsPerSample=8
16 bit signed PCM	HPI_FORMAT_PCM16_SIGNED	WAVE_FORMAT_PCM, wBitsPerSample=16
32 bit signed PCM	HPI_FORMAT_PCM32_SIGNED	WAVE_FORMAT_PCM, wBitsPerSample=32
32 bit floating point PCM (+/-1.0)	HPI_FORMAT_PCM32_FLOAT	WAVE_FORMAT_IEEE_FLOAT

5 MICROPHONE INPUT

The ASI5111 has a balanced microphone input using a ¼" stereo jack.

5.1 Phantom Power

When phantom power is enabled, +48V is present on both the + and – signal inputs (tip and ring of ¼" jack). This is used to drive professional condenser type microphones. If you are using a dynamic microphone, make sure that the phantom power is off as it may damage the mic.

User

Phantom power is turned on and off using the following control in the ASI Mixer on the Microphone panel:

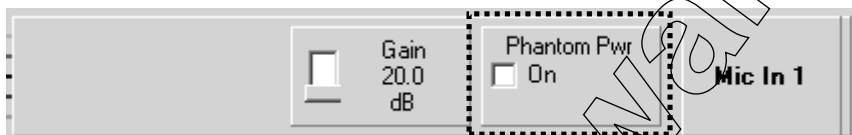

Developer

Windows – Phantom power is controlled using...

HPI – Phantom power is controlled using the `HPI_Microphone_SetPhantomPower()` API

5.2 Programmable Gain

The microphone preamp has a software programmable gain of +20, +40 or +60dB.

User

Microphone gain is adjusted using the following control in the ASI Mixer:

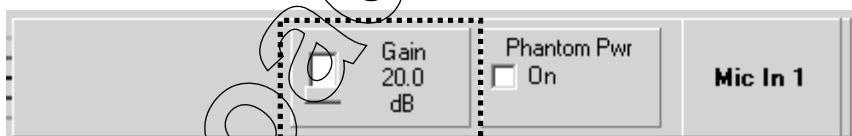

Developer

Windows – Microphone gain is controlled using...

HPI – Microphone is controlled using a Volume control on the MICROPHONE source node. Use `HPI_VolumeSetGain()` API.

6 BALANCED ANALOG I/O

The ASI5111 has a stereo balanced analog input and output on a DB-9 female connector.

6.1 Analog I/O Level

The analog Level (or Trim) is software programmable independantly for the input and output. It can be set from -10 to +20dBu in 1dB increments.

User

Analog levels are adjusted using the Trim/Level controls located on the LineIn and LineOut panels in the ASI Mixer:

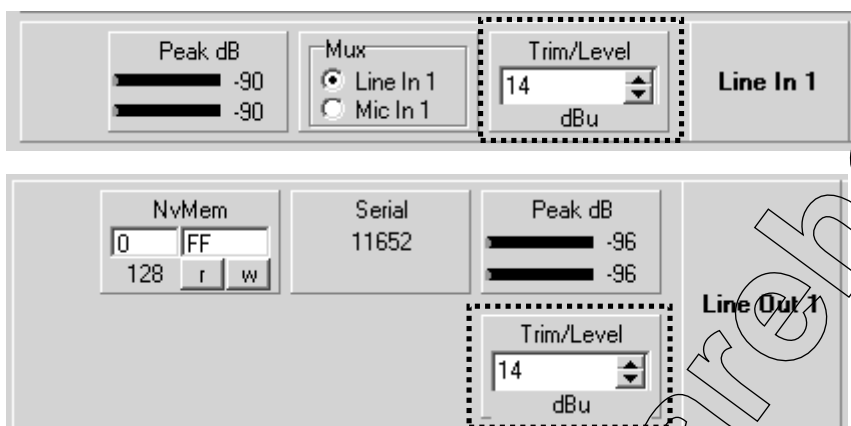

Developer

Windows – Analog levels are controlled using....

HPI – Analog levels controlled using the HPI_LevelSet() API

7 AES/EBU I/O

The ASI5111 has an AES/EBU digital audio input and output on a DB-9 male connector. This maybe also operated as S/PDIF. The AES/EBU I/O operates at either 32, 44.1, 48, 64, 88.2 or 96kHz. The bitstream contains samples of 24bit precision. When a valid AES/EBU source is connected to the ASI5111, the card will automatically generate the sample clock from that source (see Sample Clock section)

7.1 Operating as S/PDIF

The AES/EBU I/O can be operated as S/PDIF (IEC958). When this happens, the impedance of the I/O changes to 75ohms and the signal level becomes ~0.5Vpp. As well as programming the correct settings in the card, the AES/EBU signals must be connected as follows. For S/PDIF output, connect the "-" side of the AES signal to the S/PDIF shield. The "+" side becomes the S/PDIF signal.

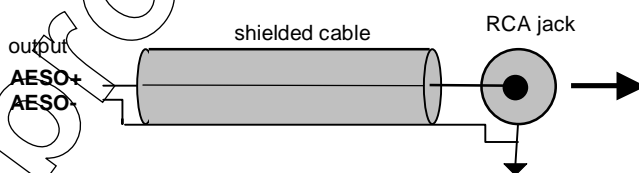

For S/PDIF input, connect the "-" side of the AES signal to the shield and ground. The "+" side becomes the signal.

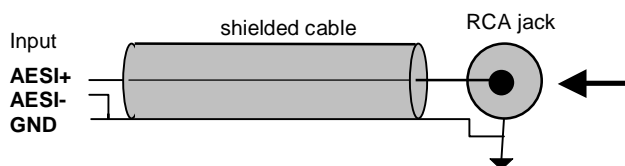

User

Use the following controls in ASI Mixer to toggle between AES/EBU and S/PDIF

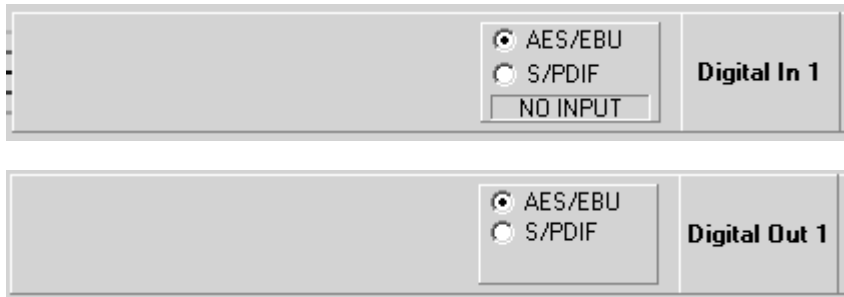
Developer

Windows – Use Digital I/O controls – see the “AudioScience WavX Specification” (SPCWAVX.PDF)

HPI – Use the HPI_AESEBU_Receiver_SetSource() and HPI_AESEBU_Transmitter_SetFormat() API

7.2 Channel Status and User Data

The ASI Mixer does not setup the Channel Status and User Data in the AES/EBU output. This must be done by the application using the following APIs:

Windows – Use Digital I/O controls – see the “AudioScience WavX Specification” (SPCWAVX.PDF)

HPI – Use HPI_AESEBU_Transmitter_SetChannelStatus() and HPI_AESEBU_Transmitter_SetUserData() APIs

Your application can also read the Channel Status and User Data of the AES/EBU input using the following APIs:

Windows – Use Digital I/O controls – see the “AudioScience WavX Specification” (SPCWAVX.PDF)

HPI – Use HPI_AESEBU_Receiver_GetChannelStatus() and HPI_AESEBU_Receiver_GetUserData() APIs

8 COMPANDER

The ASI5111 contains a compressor/expander (Compander), which is used to reduce or expand the dynamic range of the signal it acts on. It is located on the LineIn input and maybe used on both the Line In and Microphone signals.

User

The ASI5111’s Compander is accessed from the ASI Mixer by clicking on the “Compander” button on the LineIn panel. The following parameters can be set:

Compression Threshold – the input signal level at which the compression starts.

Compression Ratio – The ratio of the input signal level to the output signal level

Makeup Gain – additional gain applied the the compressed/expanded signal

Attack - Attack time of compander in milliseconds. Sets the time that the compressor takes to act.

Decay - Decay time of compander in milliseconds. Sets the time for the signal gain to return to normal after compression.

Developer

Windows – Use the Compandor control – see the “AudioScience WavX Specification” (SPCWAVX.PDF)

HPI – Use the HPI_Compandor_XXXX APIs - see the “AudioScience HPI Specification” (SPCHPI.PDF)

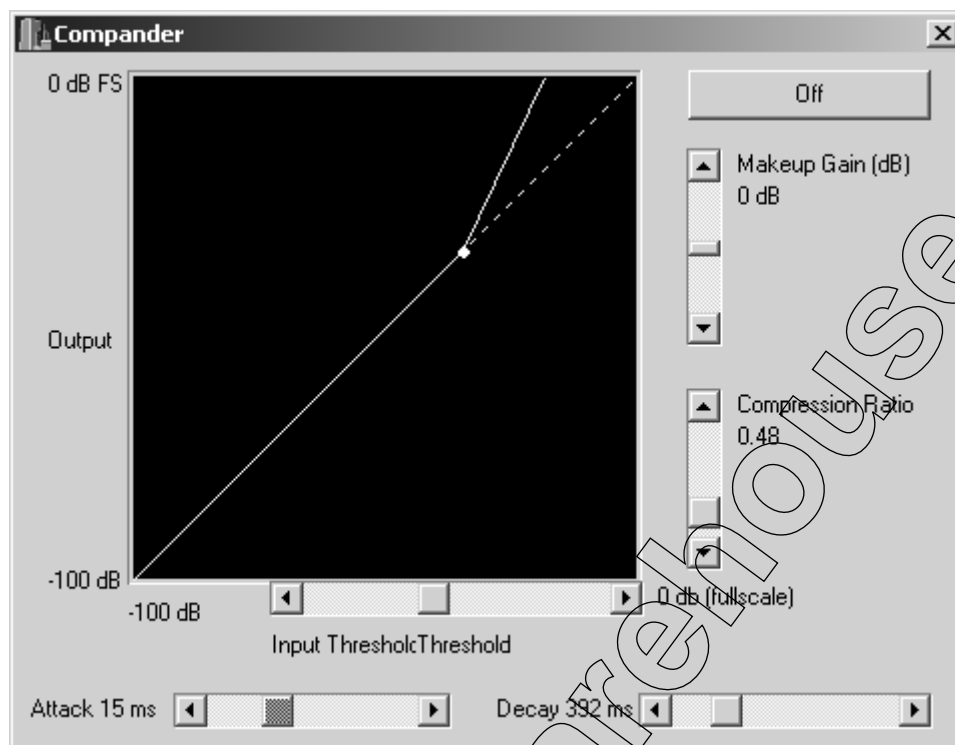

9 PARAMETRIC EQUALIZER

The ASI5111 contains a 5 band parametric equalizer. It is located on the LineIn input and may be used on both the Line In and Microphone signals. Each of the equalizers 5 bands may be individually programmed with filter type (eq, low-pass, high-shelf etc), Q (sharpness) and center frequency.

User

The ASI5111's Parametric Equalizer is accessed from the ASI Mixer by clicking on the "EQ" button on the LineIn panel. The EQ window contains controls for setting the filter parameters of each of the 5 bands, with a graph showing the combined frequency response of the 5 bands.

Each filter band has the following parameters:

Filter Type – The shape of the filter. Can be Eq (default), Lowpass, Highpass, Bandpass, Lowshelf, Highshelf.

Filter Freq – The center frequency of the filter.

Filter Q – The sharpness of the filter. The higher the Q, the more selective the filter is.

Filter Gain – The gain of the filter at the center frequency.

Developer

Windows – Use the equalizer mixer control – see the "AudioScience WavX Specification" (SPCWAVX.PDF)

HPI – Use the HPI_ParametricEQ_XXXX APIs – see the "AudioScience HPI Specification" (SPCHPI.PDF)

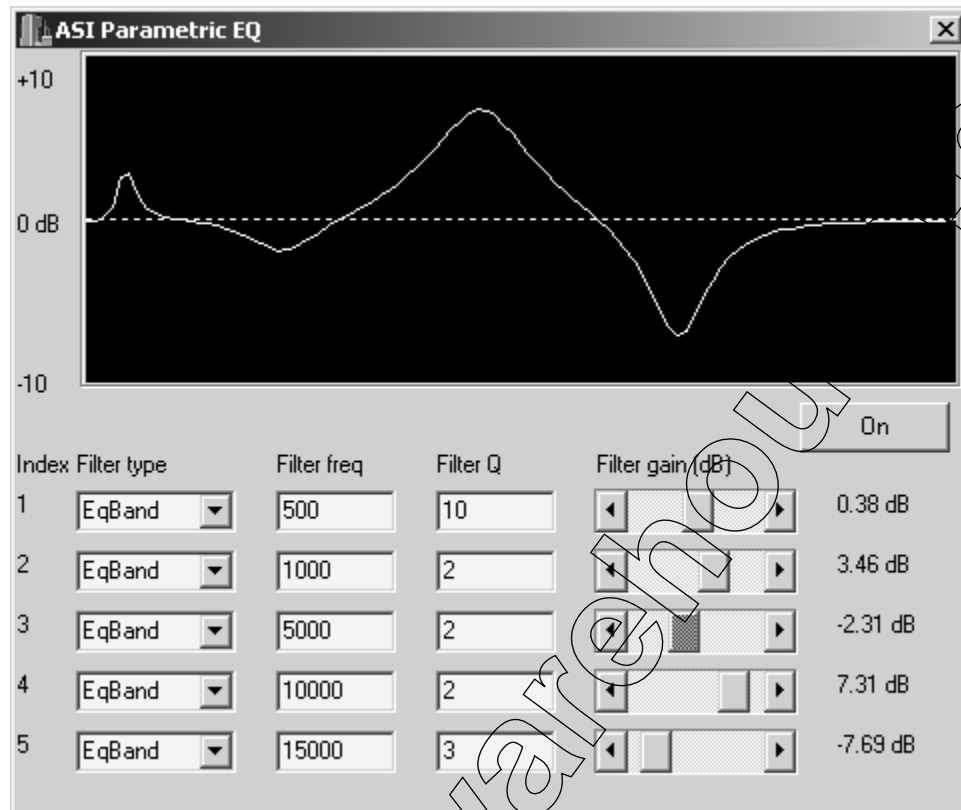

10 SAMPLE RATE CLOCK and MRX MIXER

The ASI5111 sample rate clock is used to drive the MRX digital mixer, Analog to Digital Converter (ADC), Digital to Analog Converter (DAC) and AES/EBU output. There are two sources of sample rate clock – internal and the AES/EBU input.

The internal adapter clock is generated from a low jitter frequency synthesizer and may be set to 32, 44.1, 48, 64, 88.2 and 96kHz. When a valid AES/EBU bitstream is connected to the AES/EBU input, the ASI5111 will **automatically** switch to using this as the sample rate clock. This is needed so that digital audio from the AES/EBU input can be synchronised with the other audio streams present in the mixer. There is no way to override this.

Note that the sample rate clock does not determine the sample rates of the audio streams that may be played and recorded. These are independently set using the MRX multi rate mixer, so that, for instance, you can have the adapter running at 96kHz, but be playing files of 44.1 and 48kHz and recording files of 32 and 88.2khz.

User

Use the following controls in ASI Mixer to select the internal adapter rate. Note the SampleClk source control is not user selectable as the adapter automatically switches depending whether a valid AES/EBU input is present.

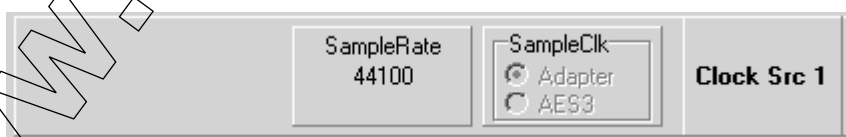

**Developer
Windows –**

HPI – Use the HPI_SampleClock_XXXX APIs.

11 CABLES

The ASI5111 comes with XLR breakout cables for both the analog and digital connectors.

12 REFERENCES

Specifications

SPCWAVX.PDF - [WavX - AudioScience Windows Multimedia Extensions](#)

SPCHPI.PDF - [Hardware Programming Interface \(HPI\) Specification](#)

All these documents are available from www.audioscience.com in the Technical Info section

[end]